



UNITRODE
APPLICATION NOTE

A SIMPLIFIED APPROACH TO DC MOTOR MODELING FOR DYNAMIC STABILITY ANALYSIS.

By
Claudio de Sa e Silva
Applications Engineer
Unitrode Corporation

When we say that an electric motor is a device that transforms electric power into mechanical power, we say two things. First, that the motor is – and behaves as – a transformer. Second, that it stands at the dividing line between electrical and mechanical phenomena. In the case of permanent magnet (PM) motors we know that this power transformation works in both directions so that the electrical impedance depends on the mechanical load, while the mechanical behavior of the motor depends on the conditions at the electrical end.

This being the case, it should be possible to represent a motor's mechanical load, on the electrical side, by a set of familiar electrical components such as capacitors or resistors.

CHOOSING A UNIT SYSTEM

Before we get started, let us consider for a moment the system of measurement units that we have chosen.

The metric system of units has undergone a number of changes in its history, of which the latest is the SI (Système International d'Unités). This system has become popular in most of the industrialized world, largely because it is a coherent system, in which the product or quotient of two or more units is the unit of the resulting quantity. It will be seen here that certain simplifications result from using this form of the metric system.

In the SI system, force is measured in Newtons (N) and distance in meters (m). Consequently, the units of torque are Nm (see Conversion Table). If a motor shaft rotates at an angular velocity of ω_M radians per second, with torque T_M , the mechanical power output will be equal to the product T_M and ω_M and the units will be watts if T_M is in Nm.

Motor manufacturers usually specify a torque constant (K_T) and a voltage constant (K_V) for their motors. These constants have different values when the torque and speed are measured in English units, but they have the same numerical value when SI units are used. This becomes obvious when you consider that the electrical input power must be equal to the mechanical output power:

$$(1) V_A I_A = T_M \omega_M \text{ (watts)}$$

$$(2) \frac{V_A}{\omega_M} = \frac{T_M}{I_A} = K_{TV}$$

where V_A is the internally generated armature voltage, or back emf. and I_A is the armature current. (See Fig. 1 for definition of motor terms.)

TABLE 1. UNITS CONVERSION

THESE UNITS	{ $\times \rightarrow =$ $= \leftarrow -$ }	SI UNITS	DIM
oz	2.78×10^{-1}	N	MLT^{-2}
lb	4.448	N	MLT^{-2}
in	2.54×10^{-2}	m	L
ft	3.048×10^{-1}	m	L
gf	9.807×10^{-3}	N	MLT^{-2}
$g \text{ cm}^2$	10^{-7}	$Nm \text{ sec}^2$	ML^2
$ft \text{ lb sec}^2$	1.356	$Nm \text{ sec}^2$	ML^2
$oz \text{ in sec}^2$	7.063×10^{-3}	$Nm \text{ sec}^2$	ML^2
ft lb	1.356	Nm	$ML^2 T^{-2}$
oz in	7.063×10^{-3}	Nm	$ML^2 T^{-2}$

NOTE: The dimensions are M (mass), L (length), and T (time). The gram (g) is a unit of mass, and the gram-force (gf) is a unit of force. The pound (lb) and the ounce (oz) are included as units of force only.

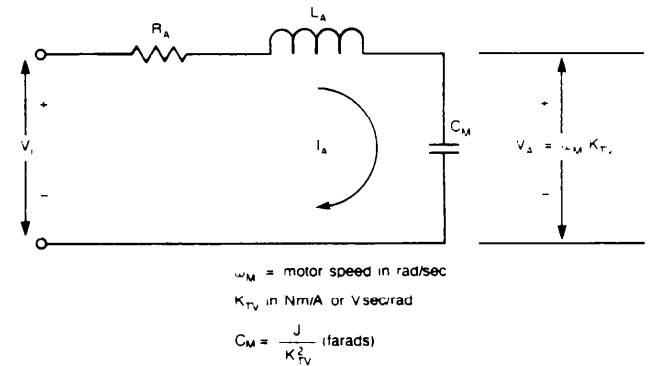

FIGURE 1. THIS SERIES RLC CIRCUIT IS AN EXCELLENT MODEL OF A DC MOTOR LOADED WITH AN ESSENTIALLY INERTIAL LOAD. HERE, J IS THE TOTAL MOMENT OF INERTIA, INCLUDING THE ROTOR'S J_M .

If we do the same thing with the familiar electrical transformer, we get the turns ratio:

$$(3) V_1 I_1 = V_2 I_2 \text{ (watts)}$$

$$(4) \frac{V_1}{V_2} = \frac{I_2}{I_1} = \frac{N_1}{N_2}$$

Thus, the non-dimensional turns ratio N_1/N_2 is analogous to the dimensional torque (or voltage) constant K_{TV} . Furthermore, equations (2) and (4) give us a clear hint that the angular velocity (ω_M) is analogous to voltage, while the torque (T_M) is analogous to current.

The units of K_{TV} may be either Nm/A. or V sec/rad. Thus, specifying both K_T and K_V for a motor is like measuring and specifying both the voltage ratio and the current ratio of a transformer, and can only make sense where redundancy is required.

THE MOTOR AS A TRANSFORMER

We have established an analogy between K_{TV} and a transformer's turns ratio; between angular velocity and voltage; and between torque and current. If the motor behaves as a transformer, then we would expect to find the square of K_{TV} involved in something analogous to impedance transformation.

Suppose we apply a constant current I_A to the armature of a motor whose load is its own moment of inertia J_M (Nm sec²). We know that according to Newton's law for rotating objects,

$$(5) \quad T_M = J_M \alpha_M$$

where α_M is the angular acceleration $d\omega_M/dt$.

Since $T_M = I_A K_{TV}$ (Eq. 2)

$$(6) \quad I_A K_{TV} = J_M \frac{d\omega_M}{dt}$$

Furthermore, also from Eq. 2,

$$(7) \quad \omega_M = \frac{V_A}{K_{TV}}$$

so that

$$(8) \quad I_A = \frac{J_M}{K_{TV}^2} \cdot \frac{dV_A}{dt}$$

Equation 6 has a familiar form, and we recognize at once the quantity J_M/K_{TV}^2 as a capacitor. It follows that the motor "reflects" a moment of inertia J_M back to the electrical primary as a capacitor of J_M/K_{TV}^2 farads.

A neat way to check this result is to equate the energy stored kinetically in J_M with the electrical energy stored in a capacitor C_M :

$$(9) \quad \frac{1}{2} C_M V_A^2 = \frac{1}{2} J_M \omega_M^2$$

$$(10) \quad C_M = J_M \left(\frac{\omega_M}{V_A} \right)^2$$

$$\text{Since } \frac{\omega_M}{V_A} = \frac{1}{K_{TV}},$$

$$(11) \quad C_M = \frac{J_M}{K_{TV}^2} \quad (\text{farads})$$

Similarly, a torsional spring with spring constant K_S (Nm/rad) is reflected as an inductance of K_{TV}^2/K_S henries. And a viscous damping component B (Nm sec/rad) appears as a resistor of K_{TV}^2/B ohms.

A MOTOR MODEL

Once we can represent the mechanical load by means of electric elements, we can draw an equivalent circuit of the motor and its mechanical load. The armature has a finite resistance R_A and an inductance L_A , through which the torque-generating current I_A must flow. These components are not negligible, and must be included. An inertially loaded motor can be represented as in Fig. 1, where the moment of inertia J is the sum of the load's J_L and the rotor's J_M .

It turns out that in practice, the moment of inertia that the motor must work against - or with, depending on how you look at it - is by far the most important component of the mechanical load. A frictional component also exists, to be sure, but because it is largely independent of speed, it would be represented electrically as a constant current source, which could not affect the dynamic behavior of the motor. And since a torsional spring - which would affect it - is rarely found in practice, we will concentrate on the inertial problem only.

MEASURING THE COMPONENTS

The measurement of R_A and L_A is not difficult. A good ohmmeter will get you R_A , and you can measure the electrical time constant τ_E to calculate L_A :

$$(12) \quad L_A = \tau_E R_A$$

Just make sure that the rotor remains stationary during these measurements.

In order to determine the value of the capacitor, C_M , we will need to measure the shaft speed. If the motor being measured is a brushless DC motor, we can use the signal from one of the Hall effect devices as a tachometer. If the Hall frequency is f_H , and the number of rotor poles is P , the angular velocity ω_M is

$$(13) \quad \omega_M = \frac{4\pi f_H}{P} \quad (\text{rad/sec})$$

With other motors you will need a strobe-light or some other means to measure speed.

A good way to measure C_M is through a measurement of the mechanical time constant T_M . We do this by driving the motor with a constant voltage driver and measuring the time it takes to accelerate from zero speed to 63% of the highest speed achievable at the voltage used. To set a safe limit to the starting current we can reduce the supply voltage or add a series resistor with the motor, or both. The set-up is shown in Fig. 2. Note that the armature resistance R_A is already known, and we add resistors R_B . If needed, to limit the armature current I_A to a value that is safe for both driver and motor.

The first thing to do is let the motor run freely and measure ω_{MAX} and I_{MAX} , and use these values to calculate the armature voltage V_{MAX} :

$$(14) \quad V_{MAX} = V_{CC} - V_{SAT} - I_{MAX} (R_A + R_B)$$

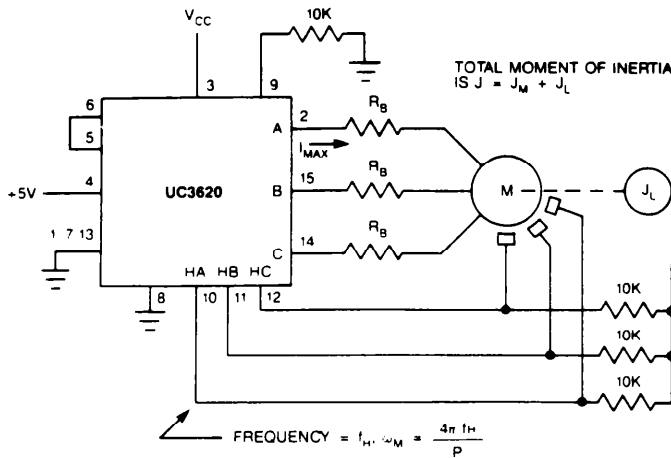

FIGURE 2. SET-UP FOR MEASUREMENT OF $C_M = J/K_{TV}$ OF A 3-PHASE BRUSHLESS DC MOTOR WITH INERTIAL LOAD J_1 . THE MOTOR VOLTAGE $V_M = V_{CC} - V_{SAT}$, WHERE V_{SAT} IS THE OUTPUT SATURATION VOLTAGE.

Here V_{CC} is the supply voltage, V_{SAT} is the saturation voltage of the driving circuit, and I_{MAX} is the current drawn by the unloaded motor at maximum speed.

Thus we can calculate

$$(15) K_{TV} = \frac{V_{MAX}}{\omega_{MAX}} \quad (\text{Vsec/rad})$$

Next, set the oscilloscope time scale to that you can easily read a Hall frequency equal to 63% of ω_{MAX} , so that:

$$(16) \omega_M = 0.63 \omega_{MAX}$$

By holding and releasing the motor shaft, take several readings of the time T_M required to accelerate from zero to ω_M . Remember that these readings are taken "on the fly," since the motor continues to accelerate towards the maximum speed ω_{MAX} . Having obtained a good value of T_M you can now calculate

$$(17) C_M = \frac{T_M}{(R_A + R_B)} \quad (\text{farads})$$

This completes the RLC equivalent circuit, If the value of J_M is also required, it too can be calculated:

$$(18) J_M = C_M K_{TV}^2$$

THE MOTOR'S TRANSFER-FUNCTION

In the circuit of Fig. 1, V_1 is the voltage applied to the motor leads, and V_A is the actual armature voltage, or back EMF. This latter voltage is equal to $\omega_M K_{TV}$, as we have seen, so that if we want to derive an expression relating the speed to the applied voltage, we can write:

$$(19) \frac{\omega_M}{V_1} = \frac{1}{K_{TV}} \cdot \frac{V_A}{V_1} \quad (\text{rad/Vsec})$$

If V_1 is a constant voltage, the speed ω_M will also be constant. This is clear from the circuit of Fig. 1 as well as from our experience with motors. If, however, V_1 varies

sinusoidally at some frequency f , the speed ω_M will vary similarly, but the amplitude and phase will in general be different from those of the driving function. This fact is very important if we are to include the motor in a feedback loop, because the motor's contribution to the overall loop gain and phase shift is an important factor in determining stability. The motor's transfer function – i.e. Eq. 19 expressed as a function of frequency – gives us a precise description of how the amplitude and phase behave at different frequencies. To do this, we use the variable $j\omega$, where $j = \sqrt{-1}$, and $\omega = 2\pi f$.

$$(20) \frac{V_A(j\omega)}{V_1(j\omega)} = \frac{(j\omega C_M)^{-1}}{j\omega^2 L_A C_M + j\omega R_A C_M + 1}$$

$$(21) \frac{V_A(j\omega)}{V_1(j\omega)} = \frac{1}{(j\omega)^2 L_A C_M + j\omega R_A C_M + 1}$$

$$(22) L_A C_M = \frac{1}{\omega_n^2}$$

where ω_n is the natural frequency of the circuit.

$$(23) R_A C_M = \frac{R_A C_M L_A}{L_A} = \frac{R_A}{\omega_n^2 L_A} = \frac{1}{Q\omega_n}$$

since the circuit Q is

$$Q = \frac{\omega_n L_A}{R_A}$$

Therefore,

$$(24) \frac{V_A(j\omega)}{V_1(j\omega)} = \frac{1}{\left(\frac{j\omega}{\omega_n}\right)^2 + \frac{j\omega}{Q\omega_n} + 1}$$

Furthermore, using Eq. 19,

$$(25) \frac{\omega_M(j\omega)}{V_1(j\omega)} = \left(\frac{1}{K_{TV}}\right) \cdot \frac{1}{\left(\frac{j\omega}{\omega_n}\right)^2 + \frac{j\omega}{Q\omega_n} + 1}$$

Since we know the values of K_{TV} , ω_n and Q , we can calculate the magnitude and phase angle of Eq. 25 for various values of $j\omega$. For a given $\omega = \omega_1$, Eq. 25 can be evaluated into a complex number $A_1 + jB_1$, whose angle is,

$$(26) \theta_1 = \tan^{-1} \frac{B_1}{A_1}$$

and whose magnitude can be expressed in decibels as follows:

$$(27) M_1 = 20 \log_{10} \sqrt{A_1^2 + B_1^2}$$

A plot of these quantities, using a logarithmic frequency scale, is called a Bode plot, and can be a handy tool in understanding how the device will affect the final loop performance.

A DISC - DRIVE EXAMPLE

A small three phase brushless DC motor, measured as above, has the following characteristics:

- $K_{TV} = 0.015 \text{ Nm/A, or Vsec/rad.}$
- $R_A = 2.5 \text{ ohm}$
- $L_A = 0.002 \text{ Hy}$
- $J = 0.001 \text{ Nm sec}_2$

The J value was measured with three magnetic discs mounted, and represents the actual value required for the application. Using Eq. 11.

$$(28) C_M = \frac{J}{K_{TV}^2} = \frac{.001}{(0.015)^2} = 4.44 \text{ fd}$$

This may seem like an unusually large value for a capacitor, but it simply reflects the large amounts of kinetic energy that can be stored in the included inertia.

From Eq. 22

$$(29) \omega_n = \frac{1}{\sqrt{L_A C_M}} = \frac{1}{\sqrt{0.002 \times 4.44}} = 10.61 \text{ rad/sec}$$

From Eq. 23

$$(30) Q = \frac{\omega_n L_A}{R_A} = \frac{10.61 \times 0.002}{2.5} = 0.0085$$

(The quality factor Q has no units). The motor transfer function, given in Eq. 25, is

$$(31) \frac{\omega_M(j\omega)}{V_1(j\omega)} = \frac{66.67}{\left(\frac{j\omega}{10.61}\right)^2 + \frac{j\omega}{0.09} + 1} \text{ (rad/Vsec)}$$

A calculator that is pre-programed to operate with complex numbers (HP 28C, for example, or 15C) makes the evaluation, of this equation an easy task. With the 28C you can set up a USER routine called BODE, as follows:

```
<<DEG DUP ABS LOG 20 X SWAP ARG>>
```

This will convert a complex number $x + jy$ into $20 \log \sqrt{x^2 + y^2}$ at level 2, and $\text{arc tan}(y/x)$ at level 1. Table 2 shows a list of several such computations of Eq. 31:

At $\omega = 0$, the gain is simply 66.67 rad/Vsec . As ω increases from zero up, the gain decreases as shown in the GAIN column of Table 2. For our Bode plot, we want to show the gain relative to the Initial, or DC, gain. Therefore, we subtract 66.67db from each gain value in Table 2 and plot the result. This is the same as plotting only the function

$$(32) G(j\omega) = \frac{1}{\left(\frac{j\omega}{10.61}\right)^2 + \frac{j\omega}{0.09} + 1}$$

which should be compared with Eq. 31. The results are shown in Fig. 3.

TABLE 2. CALCULATED VALUES OF EQUATION 31.

ω (rad/sec)	$\frac{\omega_M(j\omega)}{V_1(j\omega)}$	GAIN (db)	PHASE (deg)
0.01	65.9 - j 7.32	36.4	-6.3
0.03	60 - j 20	36.0	-18.4
0.1	29.8 - j 33.2	33.0	-48.0
0.3	5.5 - j 18.4	25.7	-73.3
1.0	0.53 - j 5.95	15.5	-84.9
3.0	0.06 - j 2.00	6.0	-88.4
10.0	0 - j 0.60	-4.4	-89.9
30.0	$-4.2 \times 10^{-3} - j 0.20$	-14.0	-91.2
100	$-4.7 \times 10^{-3} - j 0.06$	-24.5	-94.5
300	$-4.5 \times 10^{-3} - j 0.02$	-34.2	-103.5
1000	$-2.9 \times 10^{-3} - j 3.7 \times 10^{-3}$	-46.6	-128.6
3000	$-7.1 \times 10^{-3} - j 3 \times 10^{-4}$	-62.3	-157.4

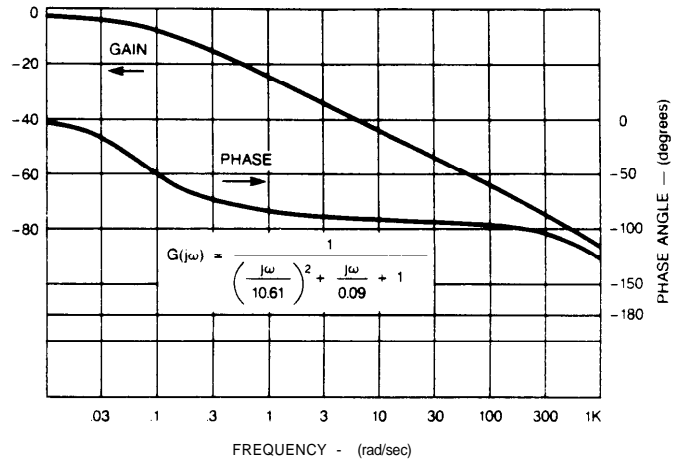

FIGURE 3. BODE PLOT OF MOTOR DATA IN EXAMPLE.

Note that up to about 100 rad/sec (15.9 Hz) the phase lag barely exceeds 90 degrees. The first pole occurs at $\omega = 0.09 \text{ rad/sec}$, at which point the phase lag is 45 degrees. The second pole, widely separated from the first in this case, occurs at a frequency in excess of 1000 rad/sec, as we can see from the further bend in the phase curve. The gain, which was drooping at a rate of -20db/dec below 100 rad/sec, now begins to bend towards a steeper droop of 40db/dec after the second pole is reached. At very high frequencies, the phase lag will reach 180 degrees.

Used in a speed control feedback loop, this motor will perform well provided that the user takes this gain and phase behavior into account. This is done by incorporating the motor transfer function into the overall loop equation, which will include other components. One's understanding of the motor's behavior improves with this type of analysis, which makes comparisons between different motors more clear and articulate.